



Please refer to the instruction manual of preparation stage to carry out the pre-treatment before applying the coating.

• Items to be used



Coating agent (Liquid I) 30ml

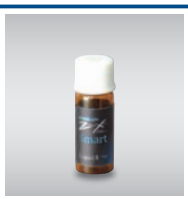

Coating agent (Liquid II) 0.5ml

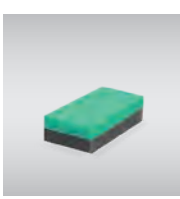

Application sponge x 1



Micro Grid Cloth (for dry wiping) x 4



Zen-Xero Accelerator

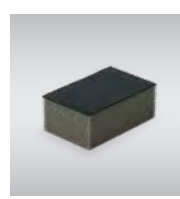

Accelerator Application Sponge x 1



Short Fiber Microfiber Cloth x 1

## 1 Mixing stage

Pour the whole Liquid II into the container of Liquid I. Then stir well and mix them completely to blend the liquids.



### Notes

- All the liquid agents must be blended completely. If the blending amount is different, it may not be able to deliver its performance.

## 2 Zen-Xero Accelerator



Although Zen-Xero can generate amazing effects by itself, it is recommended to apply the Zen-Xero Accelerator first to increase the smoothness of the painted surface. In addition, through arranging the functional group, like SiH, which can bond with the coating agent on the surface evenly, the coating agent would bond with the painted surface by chemical reaction. As a result, stronger coat formation and deeper gloss can be achieved.

Besides, by improving the smoothness of the painted surface even more, Zen-Xero's water-sliding effect will be improved as well, and water drops to stay on the surface would be reduced.

Besides, by improving the smoothness of the painted surface even more, Zen-Xero's water-sliding effect will be improved as well, and water drops to stay on the surface would be reduced.

Pour appropriate amount (5ml at first and 2-3ml as supplement) of Zen-Xero Accelerator on the Accelerator application sponge.

### Notes

- As Zen-Xero Accelerator is volatile, please close the cap tightly immediately after use.



Immediately apply it on the painted surface. Application should be carried out panel by panel.

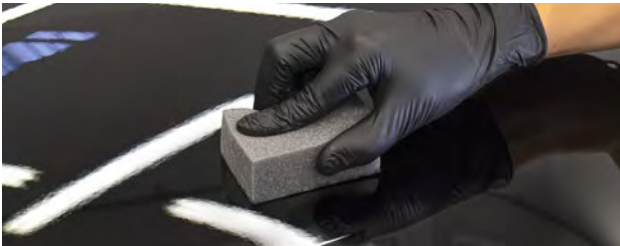

After application, use short fiber microfiber cloth to wipe and finish the process. Repeat this step at each panel.



After the application of Accelerator, please allow to dry for 20 min before applying Zen-Xero Coating agent.

### 3 Application stage

#### [Items to be used]

Mixed liquids, Application sponge

Pour 2-3ml of coating agent on the sponge.



Then start to apply it evenly and thinly on each panel of the vehicle. Make sure not to apply on the same area repeatedly as it will cause unevenness of coating. Please apply the coating quickly through both vertical and horizontal movement without missing any areas.

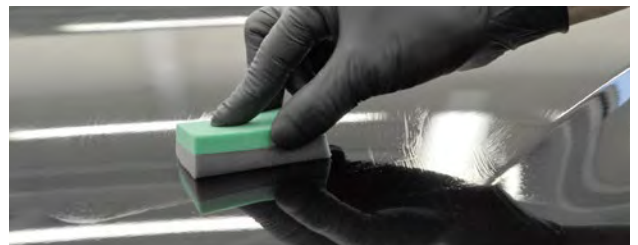

#### Notes

- Regarding large areas (like bonnet, roof, etc), please divide into 2 parts (left and right) for application.

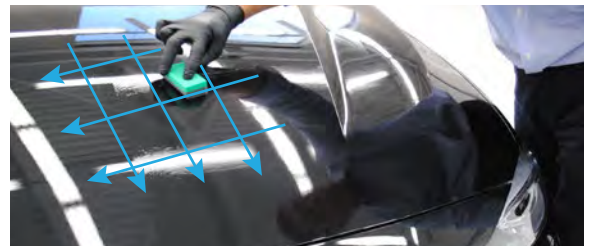



# Smart



## 4 Wiping stage

### 【Items to be used】

Micro Grid Cloth x 2

After application, immediately wipe off the surface.  
(Working temperature: 15-25°C humidity: 30-60%).

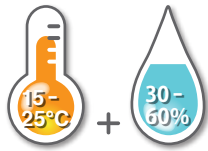

Use dry Micro Grid Cloth to wipe off the applied coating. At first, please keep wiping straightly in one direction. Then, quickly wipe off the remaining liquid.



### Notes

- Please keep changing the sides of cloth while using. Once all the sides of a cloth are used, please exchange with a new one. 3 pieces of cloth are recommended for a standard-sized vehicle.
- Please confirm the timing of wipe-off by testing at first.



- Please note that when the temperature is over 30°C, the curing time will be shortened. Thus if the wiping is delayed too long, it will be difficult to do so and may cause unevenness of coating.



Unevenness of coating caused by waiting too long



# Smart



## 5 Finishing stage

### [Items to be used]

Micro Grid Cloth x 2

Once the wiping process is roughly done, use another clean Micro Grid Cloth to achieve a beautiful finish, making sure that all the areas are completely wiped off and there is no unevenness. Continue to repeat the step 3-5 at other panels.

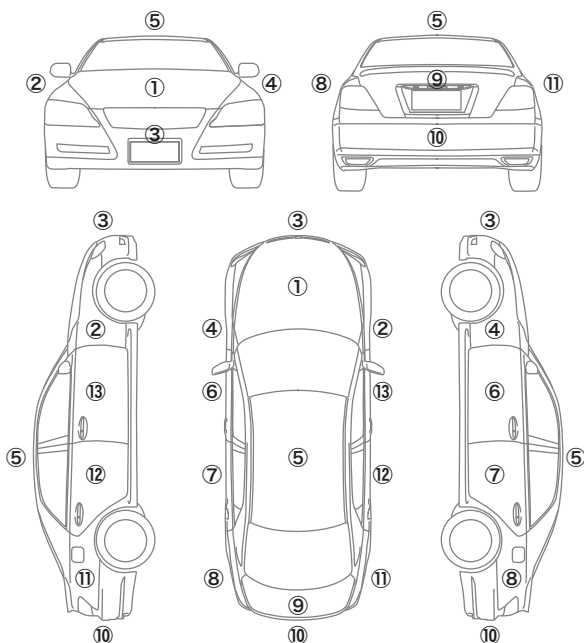

### Notes

- This product is supposed to be used for coating 1 layer normally. However, it is also applicable to 2 layers coating. Although the thickness of coat and gloss increase by repeated coating, wiping will be more difficult to be done and unevenness will easily occur, etc. Therefore, it is suggested to test before use. In addition, please finish the whole car once before applying the second coat.
- Please do not touch the surface and do not drive in the rain within 3 hours after the application. The surface of the coating will become dry in about 3 hours and completely harden in around 24 hours after the application.



## ! How to deal with unevenness of coating?

If unevenness is found after wiping or application, please polish the whole panel of that area to completely remove the coating. Then reapply the coating again.



### [Cautions for storage and handling]

- \*The unopened product should be stored at dry cool place (around 5-15°C and without direct sunlight). The shelf life of unopened product is around 8 months. If the product is stored inside the refrigerator, condensation may occur inside the container when the temperature suddenly rises and it may make the product unusable.
- \*This product is filled with nitrogen. Please immediately use after open.
- \*It is recommended to use up the liquid inside once open. However, if it is stored in a dry cool place no longer than 7 days and there is no change in color, viscosity and hardness, it can be used again. In this case, please test if there is really no change first.